

Sound Spray – can-shaped sound effect device

Gibeom Park
Music and Audio Research Group
GSCST, Seoul National University
Seoul, Korea
skymind@snu.ac.kr

Kyogu Lee
Music and Audio Research Group
GSCST, Seoul National University
Seoul, Korea
kglee@snu.ac.kr

ABSTRACT

This paper is about a development process of a novel sound effect device, which resembles ordinary spray can, with the purpose of adding sound elements to existing spray paint art. To this end, we first investigate the processes and the characteristics of spray paint art and find the common elements that can be expressed in an auditory form. We then design a prototype using Arduino and various sensors, such as force sensing resistors, accelerometers, and inclinometers, and examine the elements that would be necessary to apply the proposed device to spray paint art activities. Experiments with the prototype indicate that there is a significant potential in adding sound elements to spray paint art to enrich its artistic expressions.

Keywords

Sound effect device, Spray paint art, Arduino, Pure Data

1. INTRODUCTION

In these days, art activities do not depend on a single method. They often have many forms which are using various sensible elements multiply to arouse impressive images to one's mind. These kinds of consonance expression methods are shown up frequently in the field of Media Art. Accordingly, there have been various attempts to make transitions from already established single sensory artistic activities to multisensory activities. Especially, there are many possibilities of applying these attempts in the field of modern or nonmainstream art.

In this paper, we focus on spray paint art, and aim to add sound effects to existing form of spray paint art, as a way of developing artistic expressions from single to multisensory forms. To achieve this goal, we design a prototype that has a similar form to ordinary spray cans, and investigate the possibility of acoustic elements.

The rest of the paper is organized as follows. First, we present a brief survey of background and related work in Section 2. In Section 3, we describe the proposed system in detail, and preset the prototype in Section 4. In the following section, we discuss technical and artistic issues, followed by conclusions in Section 6.

2. BACKGROUND

Many scholars researched about sounds and colors and

Permission to make digital or hard copies of all or part of this work for personal or classroom use is granted without fee provided that copies are not made or distributed for profit or commercial advantage and that copies bear this notice and the full citation on the first page. To copy otherwise, to republish, to post on servers or to redistribute to lists, requires prior specific permission and/or a fee.

NIME '13, May 27-30, 2013, KAIST, Daejeon, Korea.

Copyright remains with the author(s).

designed the system to map the musical scales or pitches to the color spectrum of the rainbow [1]. Thus in English, noun “tone”, “volume” and “color” are used to express both sound and hue with the same expressions and similar meanings. It is closely related with stimulating association via synesthesia.

Synesthesia(or Synaesthesia) means a sensation experienced in a part of the body other than the part stimulated [2]. When human recognizes some phenomenon, each sense is separated, combined, or co-occurred to make a perception clearly.

Many people tried to find out the relation between colors and sounds and made own ways to make a relation of them. Based on Isaac Newton's “Opticks”, Scriabin arranged musical keys and colors into the circle [3]. Wells tried to find a possible link between musical harmony and visual color based on complementarity [4]. Sebba presented an experiment that examines how the organization of the sounds in a musical piece is expressed in color design [5]. Pridmore utilized electronic sound-to-light transducers to give a visual impression of music to students and deaf people [6].

On the other hand, there are studies about making new musical instruments which provide compositional expressions [7]. Garner et al. proposed a system that the creator makes his/her own contents with mobile phones, and project on the public space [8]. Scheible and Ojala made ‘virtual spray can’ using mobile phones, and added virtual drawing functions for interactive art tools for digital arts [9].

But, there are few works that aim to add sound effects to add-on devices. Also, there are few comments of auditory effects of spray cans which are built virtually.

3. PROPOSED SYSTEM

3.1 Features of spray paint art activities

We observed the working processes of spray paint artist and tried to find the common characteristics of spray paint art process. After watching many subjects, we could find some common characteristics as below.

- “spraying”, the main drawing activity
- “same and steady grip” caused by fixed position of the nozzle
- “many and various cans” for a variety of expressions
- “short working time” compare to other art works
- “dynamic usage of cans”, shake, swing, etc.
- “various usage of cans”, drawing, masking

3.2 System concept

Based on the observation of the processes of spray paint art, we established a relation between the Spray paint art's main activity, “pressing the nozzle to spray something inside the container”, and the “playing sound effects”, which can give an additional musical sense in spray paint art process.

Thus, there are several indexes of activity or status such as kinds of spray cans, kinds of nozzles, pressing pressures, inclines of spray cans, and speed or acceleration of cans. Also, there are several sound effect elements that can be linked with

activity/status indexes, such as sound sample, volume, pitch, play rate, and modulation. Linking above things to each other, the movement or status of performer is turned into the index of sound effect.

3.3 Elements Mapping

In connecting physical elements to sound elements, we intended to make an intuitive mapping that the performer could use the device without difficult instructions. Each performance elements have relations with sound effect elements as follows.

Table 1. Elements Mapping Table

Performance elements	Sound effect elements
grip/release on a can	play/stop sound
pressure of pressing nozzle	amplitude of sound effect
changing the spray/nozzle	changing sound sample
X-axis acceleration	pitch of sound effect
Y-axis acceleration	play rate of sound effect
incline of a can	low/high-pass filtering

3.4 Additional features

In order to test the applicability of being a standalone device, following features are added.

- LED spectrum light (related with background music)
- Virtual drawing (related with camera input)
- Low cost for multiple clone device

4. DEVICE PROTOTYPING

4.1 System components

Following components were used for prototyping the device.

- 1) a spray paint can(or a similar thing like a spray can)
- 2) a computer for run Pure Data
- 3) an Arduino board for process sensor input
- 4) one force sensing resistors
- 5) one clinometer
- 6) one 3-axis accelerometer
- 7) some wires, resistors, printed circuit boards, etc.

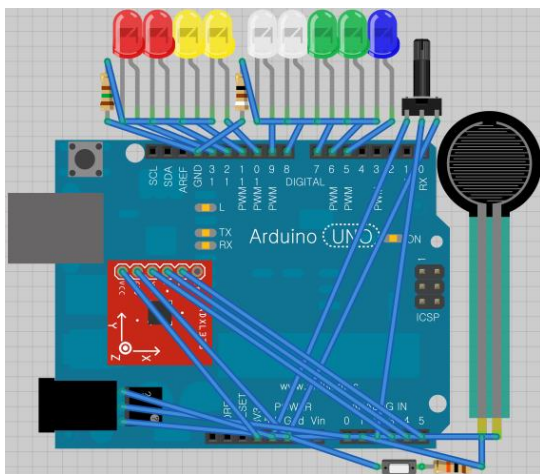

Figure 1. Components diagram

4.2 Prototype development

As a result of prototyping, the form of the realized Sound Spray is like as following images.

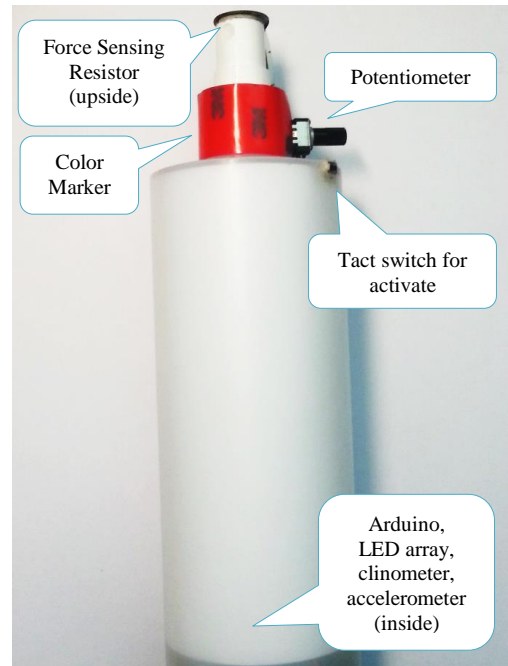

Figure 2. Sound Spray Prototype

Except components which are controllable by the performer, all the other components are placed inside the enclosure to minimize device breakdown or malfunctioning by external reasons. Although we used round-type LED for diffusing effect, concentration of lights was extreme than we expected to be. So we wrapped the enclosure with translucent paper to get an additional diffusing effect on the enclosing surface. The internal circuit diagram using Arduino is as follows.

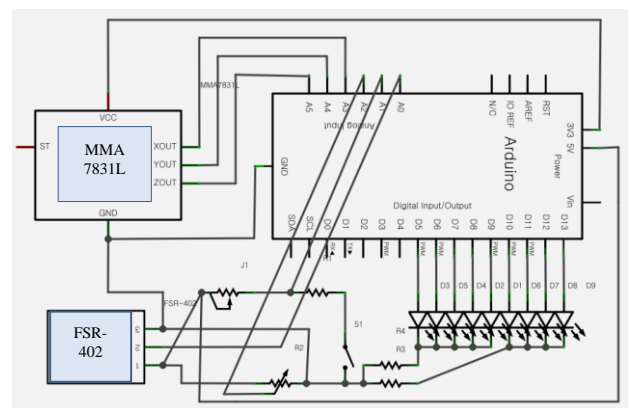

Figure 3. Circuit schematics

High-luminance LEDs are connected to the Arduino board's digital output pins with some current limiting resistors in serial. Force sensing resistor act like a variable resistor which is controlled by pressure. So it is connected with resistor in serial, then pressing pressure can be measured by the voltage difference in the connected point with Arduino board's analog input pin.

Clinometer gives continuous output voltage in right angle, and have changes in linear output voltage through left/right 60

degrees. After measuring this value through Arduino board's analog input pin, we mapped it into proper frequency range value in the Pure Data patch then applied it to cutoff frequency of low/high-pass filter.

Unlike other sensors, 3-axis accelerometer generally operates on 3.3 Volts power source. Fortunately, it is supported directly by Arduino board. X-axis(since PCB is installed in vertical direction of the device, X-axis corresponds to up-down direction) output of the accelerometer influences to the amplitude of sound effects, Y-axis(left-right) to the play rate of the sound effect. Z-axis(front-rear) is not used here, but can be used for other musical elements variously.

Because there is a potential of extreme actions and impact due to the environment where spray cans are used, the device was thoroughly assembled and fixed for durability, not to make an unpredictable problems.

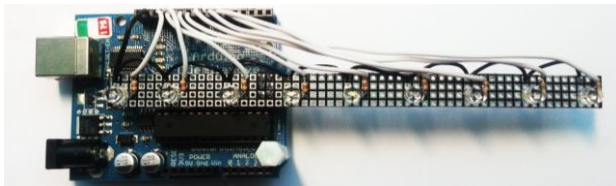

Figure 4. Arduino and LED array

4.3 Generating Sound Effects

To generate sound effects in real time, we used Pure Data. We write a Pd patch which has an interface of modifying sound elements and generate sound effects. Using synthesizer part of "Groovebox", a sequence player developed by Martin Brinkmann[10], we transformed it into useful form to Sound Spray. This can make the Sound Spray generate various sound effects by using frequency modulation, and facilitated the connections to Arduino, which will be dealt in the next chapter.

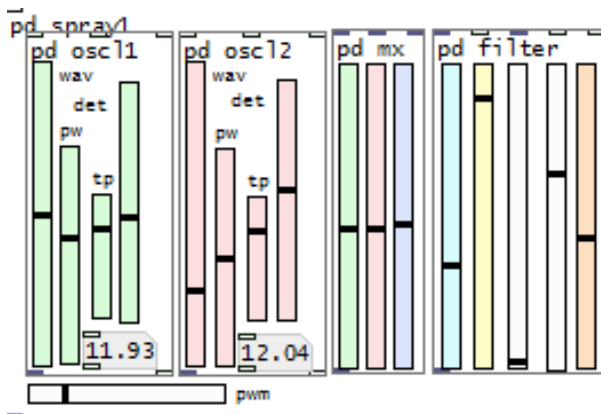

Figure 5. Interface to modify sound effects

4.4 Communicate Pure Data and Arduino

For communication between Pure Data and Arduino, we used the Firmata Protocol. On Arduino, we used Standard Firmata v2.3.3 basic code which is presented basically. On Pure Data, we used codes of Pduino v0.5 developed by Hans-Christoph Steiner to get input values from Arduino.

Through this process, we were able to change certain sound elements to generate various sound effects by received performer's input. Also, we linked LED array to amplitude of output sound and made it respond in 10db scale each, making similar effect of spectrum analyzer. Considering the

environment where a lot of spray cans are used, we also considered the linkage of multiple devices. In the situation where many devices placed respond, we would be able to get spatial lighting effects additionally.

4.5 Image processing with GEM

GEM(Graphics Environment for Multimedia) is an external plugin for the Pure Data. We added GEM codes to Pd patch and made it draw images with spray can in virtual space(display) using video input. In Pure data, due to the graphical programming language, program flexibility is low, which made it difficult to use complex methods of image processing. So we used the color recognition method that detect targeted specific color and calculate current position of Sound Spray on display, using primitive image processing commands which GEM supports basically.

For example, in the case of detecting the position of Red-colored target, after taking image data using camera, we can eliminate Green and Blue factors through their gain control. Then the factors control the gain of brightness of eliminated images and only a certain area of the targeted color which has a specific brightness range can be selected. Finally, using center of gravity of the selected area, the position of target can be calculated.

The positions of target are refreshed continuously as every new image is input. The calculated positions are represented on the display with white dots. When performer activates Sound Spray, Sound Spray draws red circles on calculated position. To get similar feelings of real spray, we used translucent circles adjusting alpha value. When circles are drawn quickly, the background image breaks through. When drawn slowly or repeatedly, circles hide the background image.



Figure 6. Virtual drawing by color recognition method

5. DISCUSSIONS

5.1 Technical issues

Through the process of making prototype device, we were able to identify that most of the technical problems from device realization were at insignificant level. The Arduino used in the prototyping has an small enough form factor that there was no problem about the size in the process. Also, sensors and other devices can be made in much smaller size. Such that, it is expected that making a Sound Spray would not be too difficult.

We also checked that making Sound Spray as a standalone device is possible enough. Instead of using the above methods of generating sound effects with Pure Data that we mentioned, we can directly use an AVR processor which is embedded on

Arduino to generate and mix the sound effects, and it is possible to get the output sounds using some parts such as piezoelectric speakers. Of course, there must be limits of producing various sound effects using only basic Arduino board. But it also could be overcome by adding extra flash memory, digital to analog converter (DAC), and amplifiers to the circuits.

However, there was considerable difficulty in making device that has add-on type enclosure which is applicable to general spray cans by assembling ready-made things. This difficulty could be solved by ordering specially designed components. To do this, some additional effort and expense will be needed for circuit design, component arrangement and enclosure modeling.

Thus, some problem was found in controlling sound effects. Firstly, force sensing resistor, which was placed on the top of the spray nozzle, was not available to make a precise measurement of the pressure because the nozzle also moved with the sensor. Instead, sensing inside the nozzle would be proper, though it needs some customizing to the sensor. Also, controlling the effects with accelerometers was not easy, either little bit unnatural. Using additional visual information would be needed to express the intended effects.

5.2 Artistic issues

In the view of artistic field, evaluation by skillful performer such as spray paint artist or street artist would be needed to verify the devices' applicability in practice. Although we have checked that most part of the technical realization is possible, due to the lack of opportunity to apply the device to practical artistic process and get feedback, it is inadequate to apply Sound Spray to artistic behavior and necessary to verify its effects. Checking what spray painters want to express through sound-added work, selecting proper methods to realize technically and getting feedback in the real art process would be needed to make the improvements of the device.

On the other hand, it also would be an almost impossible way to show artistic expressions by mapping the drawing colors and sounds directly. So other mapping strategies would be needed, such as preset of playing sounds which is controlled by the performer's motions, or live-coded by the collaborator. Then the performer can generate not only self-controlled, but also richer sounds.

6. CONCLUSIONS

In this paper, we designed spray-can-shaped sound effect device and verified the applicability in the field of spray paint art by making a prototype device. There are some limitations found in test process, but almost every function can be realized without much difficulty in technical domain. Further device elaboration process, the device will be able to 'add-on' the existing ordinary spray cans and can be used as a stand-alone device. And for expression elaborations, improving the expressiveness of the device by collaborating with related artists and getting advices would be needed. With these elaboration processes, Sound Spray can be sufficiently applicable as a sound effect device to make visual arts performing arts.

7. REFERENCES

- [1] Jewanski, Jörg. "Colour and music." *The New Grove Dictionary of Music and Musicians*, 7th Ed.(London)(in preparation) (2002).
- [2] Sultzbaugh, John S. "Chromoacoustics: The Science of Sound and Color." *The Rose* 6 (2009): 94.
- [3] Poast, Michael. "Color music: Visual color notation for musical expression." *Leonardo* 33.3 (2000): 215-221.
- [4] Wells, Alan. "Music and visual color: A proposed correlation." *Leonardo* (1980): 101-107.
- [5] Sebba, Rachel. "Structural correspondence between music and color." *Color Research & Application* 16.2 (1991): 81-88.
- [6] Pridmore, Ralph W. "Music and color: Relations in the psychophysical perspective." *Color Research & Application* 17.1 (1992): 57-61.
- [7] Dulic, Aleksandra and Keith Hamel. "Visual music instrument." *International Journal of Arts and Technology* 2.1 (2009): 22-39.
- [8] Philip Garner, Omer Rashid, Paul Coulton, and Reuben Edwards. "The mobile phone as a digital SprayCan." *Proceedings of the 2006 ACM SIGCHI international conference on Advances in computer entertainment technology*. ACM, 2006.
- [9] Scheible, Jürgen and Timo Ojala. "MobiSpray: mobile phone as virtual spray can for painting BIG anytime anywhere on anything." *Leonardo* 42.4 (2009): 332-341.
- [10] Martin Brinkmann, "GrooveBox", <http://www.martin-brinkmann.de/pd/groovebox1r3.zip>