

Portable Measurement and Mapping of Continuous Piano Gesture

Andrew P. McPherson
Centre for Digital Music, School of EECS
Queen Mary University of London
Mile End Road, London E1 4NS, United Kingdom
andrewm@eecs.qmul.ac.uk

ABSTRACT

This paper presents a portable optical measurement system for capturing continuous key motion on any piano. Very few concert venues have MIDI-enabled pianos, and many performers depend on the versatile but discontinued Moog PianoBar to provide MIDI from a conventional acoustic instrument. The scanner hardware presented in this paper addresses the growing need for alternative solutions while surpassing existing systems in the level of detail measured. Continuous key position on both black and white keys is gathered at 1kHz sample rate. Software extracts traditional and novel features of keyboard touch from each note, which can be flexibly mapped to sound using MIDI or Open Sound Control. RGB LEDs provide rich visual feedback to assist the performer in interacting with more complex sound mapping arrangements. An application is presented to the magnetic resonator piano, an electromagnetically-augmented acoustic grand piano which is performed using continuous key position measurements.

Keywords

Piano, keyboard, optical sensing, gesture sensing, visual feedback, mapping, magnetic resonator piano

1. INTRODUCTION

Electroacoustic music involving piano can face special barriers to performance. Many pieces for piano and electronics require the instrument to provide MIDI data from the keyboard and sometimes MIDI hammer actuation [18], but few concert venues provide MIDI-enabled pianos such as the Yamaha Disklavier or Boesendorfer CEUS. As a result, performers can be forced to use an electronic piano even when an excellent acoustic instrument is available.

The PianoBar [19], designed by Don Buchla in 2001 and sold by Moog Music 2003-2007, is a popular accessory in electroacoustic piano performance. An optical sensor strip rests at the back of the keyboard, generating MIDI data in response to key motion. Discontinued for several years, the PianoBar has become increasingly scarce but remains in demand as one of the few convenient, practical options for adding MIDI capability to any acoustic piano.

This paper presents a new solution for portable, detailed sensing of the performer's actions at the keyboard. The

scanner system described here aims to address the void left by the discontinuation of the PianoBar, while adding new capabilities focused on experimental electroacoustic performance and musicological research. In particular, the scanner is designed from the ground up to generate high-sample rate continuous key angle data, significantly surpassing MIDI in detail. The following sections will discuss the precedents, motivation, hardware/software design and applications of the scanner system.

2. RELATED WORK AND MOTIVATION

MIDI-enabled pianos have a long history, but few portable solutions exist, and fewer still offer any sort of extended sensing capabilities. This project aims to go beyond existing work to provide a rapidly deployable scanner which natively produces high-resolution continuous key data with automatic extraction of key touch features.

2.1 MIDI Piano Systems

Several current and discontinued systems exist for adding MIDI to the acoustic piano. The Yamaha Disklavier upright and grand pianos support MIDI sensing and playback; the Boesendorfer 290SE [17] concert grand and more recent Boesendorfer CEUS line offer similar capabilities. The PNOscan¹ optical sensor system by MIDI9 and QRS Music installs under the keyboard of an existing piano, measuring key angle by reflectance off the bottom of each key lever. The PNOscan pairs with the QRS PNOmation² retrofit kit which adds MIDI actuation (playback) capability to existing pianos. Similar aftermarket solutions are available from PianoDisc³ and other manufacturers. Installation generally requires significant time and an expert piano technician.

2.2 High-Resolution Gesture Capture

MIDI piano systems typically record only note onsets and releases (plus pedals), with a single velocity measurement for each onset. MIDI velocity is limited to 7-bit resolution, though the Boesendorfer CEUS supports 8-bit velocity measured directly from the hammers [1]. The CEUS also supports continuous key angle measurement at 8-bit resolution and 500Hz scan rate [1]. Our own previous work [13] electrically modified a Moog PianoBar to produce continuous key angle measurements with similar resolution (subject to limitations discussed in Section 3.1).

Continuous key angle can be used to generate MIDI, but it has other uses as well. Notes played percussively (finger striking the key in motion) generate a different pattern of key motion than notes played non-percussively (finger beginning at rest on the key) [5], and because of the felt

¹<http://www.midi9.com/products.htm>

²<http://www.qrsmusic.com/PMII.asp>

³<http://www.pianodisc.com>

Permission to make digital or hard copies of all or part of this work for personal or classroom use is granted without fee provided that copies are not made or distributed for profit or commercial advantage and that copies bear this notice and the full citation on the first page. To copy otherwise, to republish, to post on servers or to redistribute to lists, requires prior specific permission and/or a fee.

NIME'13, May 27 – 30, 2013, KAIST, Daejeon, Korea.

Copyright remains with the author(s).

between key and key-bed, key pressure produces a measurable change in position [15] allowing aftertouch effects to be derived from key angle. Continuous key measurement also enables extended techniques including partial presses, taps, and vibrato which have no meaning in traditional acoustic performance [13].

Many other sensor modalities have been used to measure keyboard performance, a full discussion of which exceeds the scope of this paper. Several authors use conventional or high-speed video motion capture to track the movement of a pianist’s fingers and hands [6, 12, 7] or arms, torso and head [2, 20]. Others have employed the Kinect depth-camera for analyzing traditional performance [9] or adding new techniques [23]. Accelerometers [10, 8] and force sensors [8] have been used to track arm and finger motion. Other work uses capacitive touch sensing to measure the location of finger-key contacts [17, 14].

2.3 Moog PianoBar

The Moog/Buchla PianoBar is unique among existing systems in its straightforward, rapid setup. The PianoBar uses optical reflectance sensing to measure the white keys and beam-interruption sensing on the black keys. A separate magnetic proximity sensor measures the position of the left (*una corda*) and right (damper) pedals. LEDs within the keyboard sensor bar indicate active notes, with orange LEDs used for the white keys and green LEDs for the black keys.

Unlike most systems which are tied to a specific instrument or require lengthy setup and calibration, the PianoBar can be deployed in less than 5 minutes. In addition to MIDI output, its onboard synthesizer provides a variety of sounds, though this feature seems to be rarely used in the electroacoustic music community.

2.4 Motivation: Beyond the PianoBar

The system presented here aims to combine the rapid deployment of the PianoBar with extended sensing and visual feedback features. Goals include:

1. **Continuous key angle** at high temporal and spatial resolution, from which MIDI data can be derived as needed.
2. **Real-time extraction of key touch features** associated with aspects of keyboard technique that go beyond velocity. These include percussiveness [5] (pressed vs. struck keys) and aftertouch (key pressure).
3. **Flexible mapping options** from key motion to sound, building on common protocols such as Open Sound Control [21] and augmented instruments such as the magnetic resonator piano [13].
4. **Rich visual feedback** from RGB LEDs above each key, providing contextual information beyond note on/off.
5. **Physical portability** including the ability to pack down in pieces for easier travel.

In exchange for these features, several capabilities of other systems were deemed less important. Direct hammer measurement (as found in the Boesendorfer instruments) and extended sensing capabilities (capacitive/video etc.) were impractical within the setup and portability constraints. Hardware audio synthesis (as found in the PianoBar) was not a priority. The height of the PianoBar scanner can be accidentally changed when bumped, so a more secure adjustment mechanism was desired, even if this required

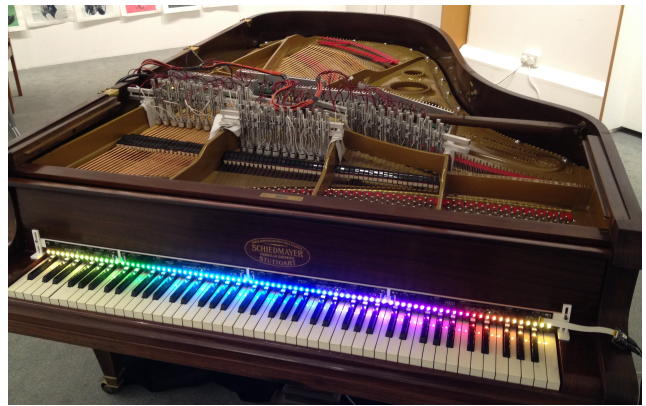

Figure 1: Optical scanner hardware. Top: scanner showing all RGB LEDs active, set up on the magnetic resonator piano. Bottom: optical sensors over each key. White stickers are attached to the black keys to increase their reflectance.

a somewhat longer setup time. Finally, since most current practice uses computer processing rather than hardware MIDI synthesis, a USB connection was preferred to the MIDI ports found on many systems.

3. HARDWARE DESIGN

Figure 1 shows the scanner design, which features four circuit boards attached to an acrylic mounting bracket. Each board covers roughly two octaves of sensors (25 for the top board, which includes the high C, and only 15 for the bottom board).

3.1 Optical Sensors

Near-field optical reflectance sensing is used to measure the position of each key. Fairchild QRE1113 sensors, which include an LED and a phototransistor in a compact package, are mounted across the bottom edge of each board (Figure 2). Figure 3 shows a schematic of the sensor circuit. The collector of the phototransistor OPTO1 attaches directly to the inverting input of an operational amplifier IC1A. Since the voltage at this point is fixed at V_{ref} by op-amp feedback, the circuit mitigates any effects of parasitic capacitance in the transistor, which improves response speed compared to using a pull-up resistor on OPTO1. Resistors R2-R3 produce $V_{ref} = 1.98V$. R4 and R5 set the resting voltage $V_{ref} - (3.3V - V_{ref})R5/R4 = 0.22V$ and

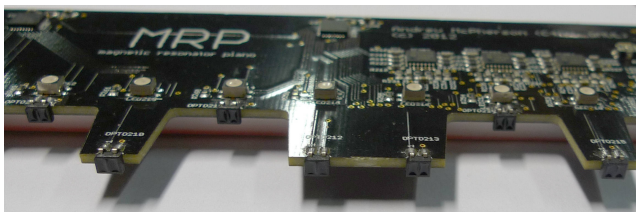

Figure 2: Reflectance sensors on the bottom of the scanner are identical for black and white keys. Each sensor contains an LED and phototransistor in a compact package.

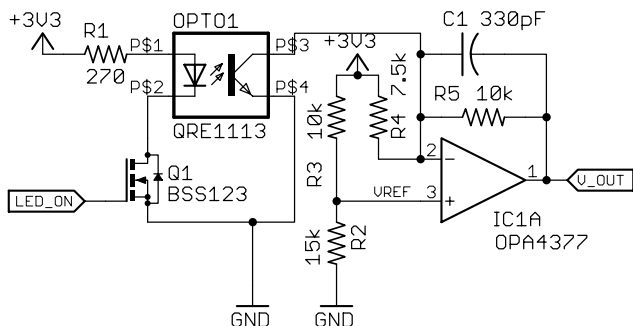

Figure 3: Schematic of optical reflectance sensors. Multiple sensors can be included on one op-amp channel by selectively activating each LED.

the transconductance (10V/mA). C1 filters high-frequency noise and ensures stability. IC1 is a rail-to-rail part which can output up to the 3.3V supply.

Since phototransistor current is nearly linear with received light, the output voltage will likewise be proportional to light, which roughly follows the inverse square of the key-sensor distance. Transistor Q1 switches the emitter on and off. Differential measurements of V_{out} with Q1 on and off compensate for ambient lighting. Additionally, by using separate transistors on each LED, multiple detectors can be combined on the same op-amp channel, reducing the number of analog-to-digital converter inputs needed.

An important difference from the Moog PianoBar concerns the treatment of the black keys. On the PianoBar, emitter and detector are placed on opposite sides of the key, such that the key interrupts the beam when at rest (Figure 4). Though this is sufficient for MIDI (on/off) data, the arrangement cannot sense continuous key position over the entire key range. Our previous work modified the PianoBar to extract continuous sensor values [13], but many of the novel mappings which depended on full-range key position were only possible on the white keys. When this sensor was applied to electromagnetically augmenting the acoustic piano, the counterintuitive result was that certain keys and tonalities were favored over others, since not every key could execute every technique.

By contrast, the new scanner uses identical reflectance sensors on every key. Since the black keys do not reflect enough light to be reliably measured, removable white stickers are affixed to them before the scanner is installed (Figure 1, bottom). The process adds 2-3 minutes to the setup time, but the higher data quality easily outweighs this drawback.

Sensor data is reported at 1kHz sample rate for each key. Each sample is the average of 8 differential measurements

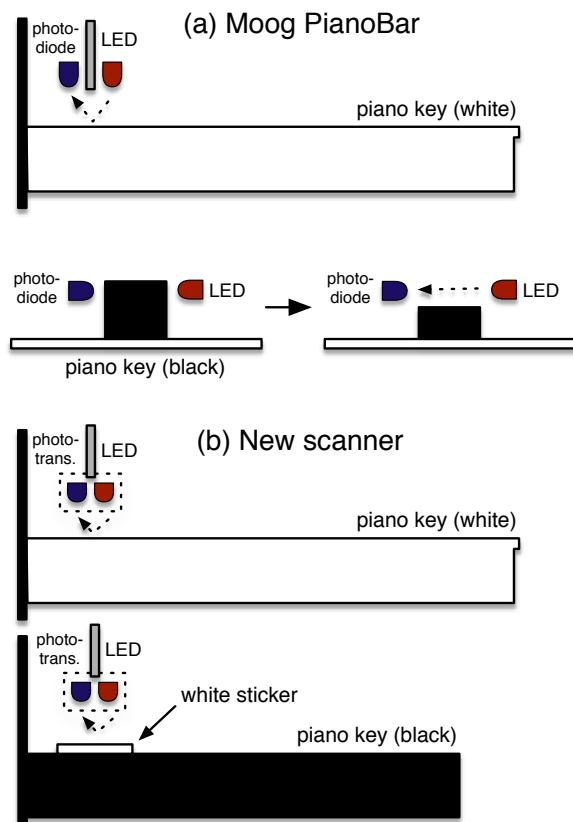

Figure 4: Optical sensing architecture for (a) Moog PianoBar and (b) new scanner. The PianoBar uses beam-interruption sensing on the black keys which does not allow measurement of continuous key angle. The new design uses identical reflectance sensors on each key.

(8 measurements LED on, 8 measurement LED off), with 12-bit resolution.

3.2 RGB LEDs

The PianoBar included monochrome LEDs over each key (orange on the white keys, green on the black keys). In our augmented piano system [13], performers often asked what the colors meant, suggesting that multicolored LED feedback could provide useful additional information. The new scanner includes RGB LEDs above each key which can be set to arbitrary hue, saturation and brightness. A cascade of five TLC5940 chips is used on each board to control the LEDs (red, green and blue elements for 25 LEDs = 75 independent channels). Section 5.3 discusses mappings between key motion and LED color, but any relationship is possible, including setting LED colors independently of keyboard actions.

3.3 Controller and Communication

Each of the four sensor boards includes a STM32F103 microcontroller, which features a 72MHz ARM Cortex-M3 core. The boards communicate with one another through a shared high-speed SPI serial interface. The board at the top register of the piano acts as the master controller for the remaining boards, and it provides USB communication with the host computer. The scanner appears to the host as a USB-serial device, and a custom binary protocol is implemented for exchanging frames of data. In practice, data

rates of approximately 2Mbps are required to stream values for every key at 1kHz sample rate. This is easily within the 12Mbps capability of full-speed USB.

3.4 Mechanical Setup

Portability was an important design goal. The Moog PianoBar is by far the most portable of any existing MIDI conversion solution, but its length still makes it difficult to transport. The new scanner uses a two-piece plastic bracket which can be taken apart for transport. The folded length of the scanner is approximately 26 inches. Like the PianoBar, each board can be moved slightly from side to side to accommodate differing key spacings. Nuts are used to securely fix the height of the scanner. Since the design is modular, keyboards of different sizes such as the 97-key Boesendorfer Imperial Grand can be accommodated by substituting different board sizes.

3.5 Future Developments

Pedal sensing remains to be implemented on the current hardware. Experimental prototypes show that optical reflectance can be used on the pedals, and measurement of all three piano pedals (as opposed to two on the PianoBar) will be straightforward.

4. REAL-TIME DATA ANALYSIS

This project aims to provide *multidimensional* key gesture sensing on any piano. Continuous key angle data significantly exceeds the level of detail provided by MIDI, and as described in Section 2.2, it can be used to derive several features of each key press. Prior to use, the scanner is calibrated by pressing each key to set the minimum and maximum values. From this point, in addition to raw sensor data, each new note onset generates several features:

- **Velocity**, similar to MIDI, but the point of measurement (“escapement point”) can be changed programmatically unlike other scanners. For example, a shallower escapement point will respond more quickly to new key presses. Resolution of the measurement is not limited by 7-bit MIDI.
- **Percussiveness**, which includes several features related to the initial velocity spike that struck keys exhibit [15]. This includes magnitude and location of the initial velocity spike and the relative amount that the key position changed before and after the spike. An overall percussiveness score is also calculated which can be mapped to an independent dimension of sound production. Previous work [15] showed that performers can control percussiveness and velocity independently.
- **Aftertouch** or **weight** which measures the amount of force the player exerts on the key-bed. This can be a single score immediately following note onset (the deepest point of the key throw) or can be measured continuously throughout a key press.
- **Release velocity**, supported by the MIDI standard but rarely implemented, measures the speed of key release. This is calculated identically to onset velocity at a user-definable position threshold. Release velocity is relevant to acoustic piano performance since it changes the speed at which the damper returns to the string.

Figure 5 shows a plot of key motion with these features; these plots are generated in real time from the controller

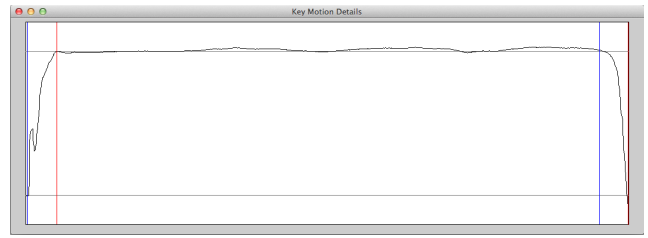

Figure 5: Continuous key position for a single note showing percussiveness (spike at beginning) and aftertouch (position variations at full press). Blue/red vertical lines indicate beginning and end of press and release phases.

software. Internally, the software operates a state machine which tracks the motion of each key (Figure 6). The state machine follows each minimum and maximum of the key motion, enabling the detection of partial presses and taps which fall below the traditional note onset threshold. It also segments the beginning and the end of both onset and release phases (blue/red vertical lines in Figure 5) to assist feature calculation. From this framework, further algorithms can be implemented to detect extended techniques including key vibrato (Figure 7, Section 5.2).

The software framework is implemented in C++ with a modular architecture that allows new mappings to be rapidly developed and deployed. All sensor data and state transitions are timestamped and processing is independent of the sensor sample rate. The specific scanner hardware can thus be separate from the feature extraction, potentially enabling the framework to work with other continuous key angle sources such as the Boesendorfer CEUS. Conversely, data can be logged for later analysis in the manner of [1].

5. MAPPINGS

The scanner is intended to be a flexible device for capturing the expressive details of keyboard technique. It is expected that every user will develop their own mappings, either based on a reduced set of MIDI features or on high-resolution native features communicated by Open Sound Control. This section describes several initial mappings, including application to the magnetic resonator piano [13], an electromagnetically-augmented acoustic piano on which the performer can continuously shape the sound of each note.

5.1 MIDI Mappings

Since MIDI remains the native format for many systems, onset and release can be transmitted as MIDI. Key pressure, as detected by subtle variations in position when the key is fully pressed, is transmitted as polyphonic aftertouch. MIDI release velocities are also supported. The software can act as a virtual MIDI source for other programs.

A novel MIDI mapping is the use of the percussiveness feature to trigger a second instrument. In this mode, each key press generates MIDI notes on two channels. The first channel retains the standard behavior, where on the second, the onset velocity corresponds to the percussiveness of the note. An example musical application uses a sustained voice with slow attack (e.g. strings) on the main channel and a short, percussive sound (e.g. marimba) on the percussiveness channel. In this way, the type of key touch creates a readily apparent variation in the output sound quality.

Percussive and non-percussive touches appear in every piano performance, but they do not produce a significant acoustic distinction in traditional performance [4]. Mapping

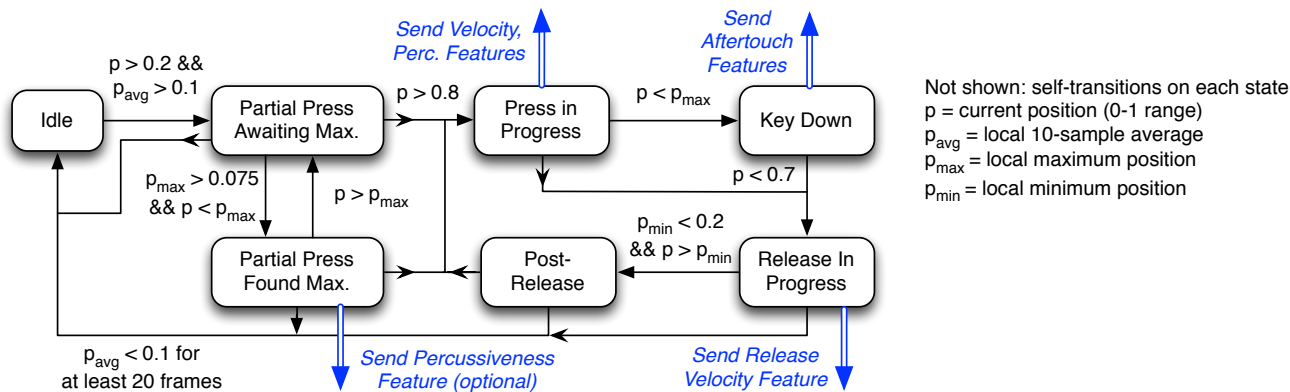

Figure 6: State machine which tracks continuous key position to generate key press features.

this dimension to sound production is in line with Lähdeoja et al.’s proposal to use ancillary performance gestures for instrument augmentation [11].

5.2 Magnetic Resonator Piano

The magnetic resonator piano (MRP) is an augmented acoustic instrument which places electromagnets over every string of a grand piano. By running a time-varying current through an electromagnet, the string can be made to produce indefinite sustain, crescendos, pitch bends, harmonics and new timbres, all without being struck with the hammer. Development of the instrument began in 2009. Since that time, it has undergone one complete redesign and several rounds of polishing in response to collaborations with composers and performers [16]. Figure 1 (top) shows the scanner on the latest MRP system.

Continuous key motion is foundational to MRP technique, and this scanner for the first time enables a full complement of extended techniques to be used on both black and white keys. Several mappings have been developed which depend on key position, velocity, and the state of the detection system (Figure 6).

Key position in the *partial press* states determines the intensity of the note. Intensity is an intermediate parameter which can in turn be mapped to changes in amplitude and spectral content. In the *down* state, aftertouch engages a second *brightness* dimension which scales with key pressure. Brightness is in turn mapped to the spectral centroid of the electromagnet waveform, pushing the energy higher up in the harmonic series to make a brighter sound. In the *release* state, intensity again depends on position, enabling gradual releases. Because piano keys bounce slightly after release, the *post-release* state is implemented to suppress any sound production from these unwanted motions.

Key vibrato is an extended technique made possible by the scanner (Figure 7). When the (low-pass filtered) key velocity exhibits periodic positive and negative peaks spaced less than 300ms apart, the vibrato mapping is engaged. Vibrato causes a progressive increase in the pitch of the note, which moves stepwise up the harmonic series of the string. In this way, tapping repeatedly on the key or oscillating it between thumb and forefinger causes a shimmering effect as the string rings at each of its harmonics.

Other mappings break down the traditional independence of the keys. On non-keyboard instruments, the sound of a note is strongly affected by what preceded it and what else sounds simultaneously. On the MRP, when one key is held down and the key 1 or 2 semitones away is touched lightly, a pitch bend connects the first and second notes. The bend is proportional to the position of the partially pressed key,

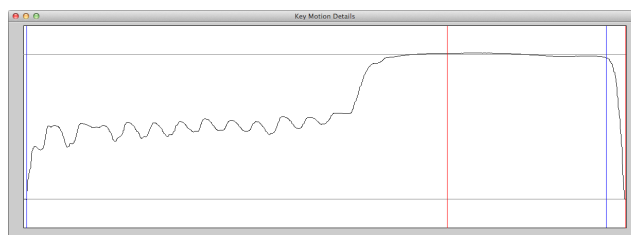

Figure 7: Key position for a note played with a vibrato gesture, which produces a harmonic glissando on the magnetic resonator piano.

enabling detailed control of portamento effects.

5.3 LED Feedback Mappings

LED intensity and color can provide useful visual feedback not only on the raw key position, but on the underlying state of more complex sound mapping systems. In MIDI mode, initial key touches produce a green light. When the key reaches the key bed, further pressure (aftertouch) alters the hue of the LED, moving toward red at maximum pressure (Figure 8 top). Notes played percussively begin with a blue flash to indicate the different touch.

The magnetic resonator piano adds further mappings, including scaling LED brightness with key position for partial presses. Pitch bend gestures, which always involve two or more keys, shift the hue toward the blue end of the spectrum (Figure 8 bottom), with green indicating no bend and violet indicating bend of over 1 full semitone. Harmonics produced by vibrating the key cycle rapidly through the hues with a lower color saturation (i.e. a whitish tint). These visual mappings highlight the activation of the extended techniques and help the performer regulate their execution.

5.3.1 Other Potential LED Applications

Since the LEDs can be arbitrarily controlled by software, their use potentially extends beyond feedback on key motion. Further applications might include automated piano tutoring [3], where LED color can guide the performer to the next note and indicate correct/incorrect performance, or remote collaboration between pianists [22] where LEDs could compactly indicate the remote performer’s actions.

6. CONCLUSION

This paper has presented a new portable optical keyboard scanner for measuring the expressive nuances of piano performance. The scanner is portable and installs on any piano,

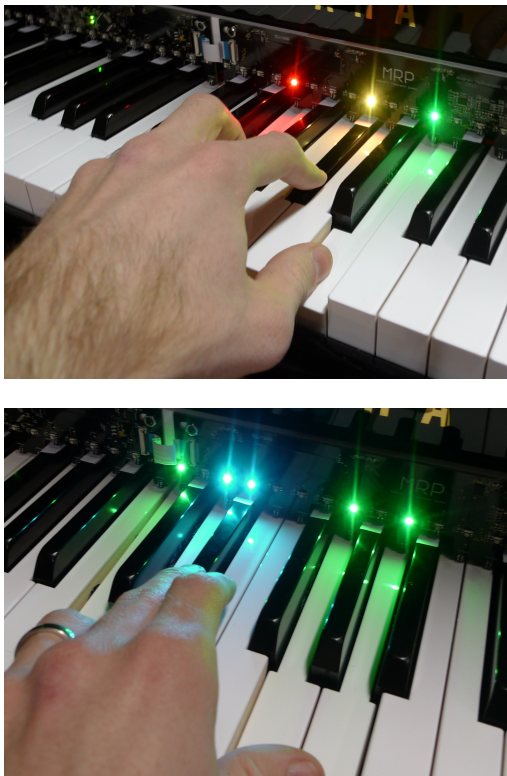

Figure 8: LED color feedback. Top: green to red corresponds to minimum to maximum aftertouch pressure. Bottom: multi-key pitch bend shifts the color toward blue.

filling a niche left vacant by the discontinuation of the Moog PianoBar. The scanner significantly extends the capabilities of the PianoBar and other MIDI systems by reading continuous key position and providing multicolor LED feedback. Continuous key position has been shown to be useful for quantifying different types of key touch and enabling novel extended techniques. The system can support the needs of many electroacoustic pieces involving piano while encouraging new creative ways of interacting with the instrument.

7. ACKNOWLEDGMENTS

Thanks to Youngmoo Kim and Jeff Gregorio at Drexel University for help with testing and mapping. This work is partly supported by a Research Grant from the Royal Society (RG110587).

8. REFERENCES

- [1] M. Bernays and C. Traube. Piano touch analysis: A MATLAB toolbox for extracting performance descriptors from high-resolution keyboard and pedalling data. In *Proc. JIM*, 2012.
- [2] G. Castellano, M. Mortillaro, A. Camurri, G. Volpe, and K. Scherer. Automated analysis of body movement in emotionally expressive piano performances. *Music Perception*, 26(2):103–120, 2008.
- [3] R. Dannenberg, M. Sanchez, A. Joseph, P. Capell, R. Joseph, and R. Saul. A computer-based multi-media tutor for beginning piano students. *Journal of New Music Research*, 19(2-3):155–173, 1990.
- [4] W. Goebel, R. Bresin, and A. Galembo. Once again: The perception of piano touch and tone. Can touch

audibly change piano sound independently of intensity? In *Proceedings of the International Symposium on Musical Acoustics*, 2004.

- [5] W. Goebel, R. Bresin, and A. Galembo. Touch and temporal behavior of grand piano actions. *Journal of the Acoustical Society of America*, 118:1154, 2005.
- [6] W. Goebel and C. Palmer. Temporal control and hand movement efficiency in skilled music performance. *PloS one*, 8(1):e50901, 2013.
- [7] D. Gorodnichy and A. Yogeswaran. Detection and tracking of pianist hands and fingers. In *Proc. Canadian Conf. on Computer and Robot Vision*, 2006.
- [8] T. Grosshauser, B. Tessorodorf, G. Tröster, H. Hildebrandt, and V. Candia. Sensor setup for force and finger position and tilt measurements for pianists. In *Proc. SMC*, 2012.
- [9] A. Hadjakos. Pianist motion capture with the kinect depth camera. In *Proc. SMC*, 2012.
- [10] A. Hadjakos, E. Aitenbichler, and M. Mühlhauser. Probabilistic model of pianists’ arm touch movements. In *Proc. NIME*, 2009.
- [11] O. Lähdeoja, M. M. Wanderley, and J. Malloch. Instrument augmentation using ancillary gestures for subtle sonic effects. In *Proc. SMC*, 2009.
- [12] J. MacRitchie and N. J. Bailey. Efficient tracking of pianists’ finger movements. *Journal of New Music Research*, 42(1), 2013.
- [13] A. McPherson and Y. Kim. Augmenting the acoustic piano with electromagnetic string actuation and continuous key position sensing. In *Proc. NIME*, 2010.
- [14] A. McPherson and Y. Kim. Design and applications of a multi-touch musical keyboard. In *Proc. SMC*, 2011.
- [15] A. McPherson and Y. Kim. Multidimensional gesture sensing at the piano keyboard. In *Proc. CHI*, 2011.
- [16] A. McPherson and Y. Kim. The problem of the second performer: Building a community around an augmented piano. *Computer Music Journal*, 36(4), 2012.
- [17] R. A. Moog and T. L. Rhea. Evolution of the keyboard interface: The Bösendorfer 290 SE recording piano and the Moog multiply-touch-sensitive keyboards. *Computer Music Journal*, 14(2):52–60, Summer 1990.
- [18] X. Pestova. *Models of interaction in works for piano and live electronics*. PhD thesis, McGill University, 2008.
- [19] Piano Bar. Products of interest. *Computer Music Journal*, 29(1):104–113, 2005.
- [20] M. Thompson and G. Luck. Exploring relationships between pianists’ body movements, their expressive intentions, and structural elements of the music. *Musicae Scientiae*, 16(1):19–40, 2012.
- [21] M. Wright and A. Freed. Open sound control: A new protocol for communicating with sound synthesizers. In *Proc. ICMC*, 1997.
- [22] X. Xiao. MirrorFugue: Communicating hand gesture in remote piano collaboration. In *Proc. TEI*, 2011.
- [23] Q. Yang and G. Essl. Augmented piano performance using a depth camera. In *Proc. NIME*, 2012.